

intel

Digital Home Integration Initiative

intel

Today's Goals

1. State of the Industry
2. Profile of "Digital Home" Customers
3. Sales Strategies
4. Marketing Allies
5. Dynamics of Residential Projects
6. Product Sources

intel

Analog/Digital Convergence "Video Technology"

That was then.....this is NOW!

intel

Analog/Digital Convergence "Audio Technology"

Then..... NOW!

intel

Analog/Digital Convergence "Content"

Movielink™

intel

Evolution of the Family Room



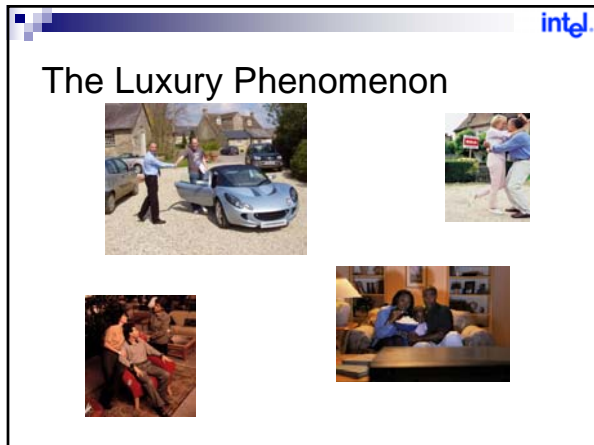

Success Stories

LEVIS
Capital E. £350

intoto kitchens
25 Locations in Southern UK

Callaway GOLF

STARBUCKS COFFEE
432 - England

britannia
Taste is everything

Harry Ramsden's
Since 1928

VW
Phaeton £76,000

*Other names and brands may be claimed as the property of others.

intel

Emotional Triggers

<p>Taking Care of ME</p> <ul style="list-style-type: none"> Stress Relief Comfort Health 	<p>Connecting</p> <ul style="list-style-type: none"> Family Love Sex
<p>Questing</p> <ul style="list-style-type: none"> Reinvention Adventure Journey 	<p>Individual Style</p> <ul style="list-style-type: none"> Dream Big You're Invited Success

intel

Top Spending Category





"HOME" – The New Luxury Frontier

intel

Sub-categories

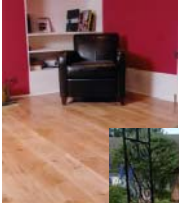

- Furniture
- Garden
- Re-modeling
- Flooring
- Art
- Home Technologies
- Appliances

intel

Why.....

- Connecting
- Taking Care of Me
- Personification of the Owner
- Questing





intel

Range Cookers



- Started in 1777
- 1803 moved to Leamington Spa
- *"the most ready means of performing in the best manner, either separately or at the same time, all the operations of cooking with only one fire, and that an open one, which may be of any size to suit the kitchen of the smallest cottage, or the largest mansion or hotel.... its arrangement is so simple, in every department of the culinary process, that servants cannot easily disorder or mismanage it."*
- 2002 invested £3 million to depart from "production lines"
- Re-Capture the art of cooking
- Aga Foodservice Group
- £ 1,800 to £ 2,000



Rangemaster 110

*Other names and brands may be claimed as the property of others.

intel

High-End Positioning



- "Taste is Everything"
- "We're passionate about taste"
- Britannia SI12TC6X2SLXS
- £ 3,295 – £ 4,199





*Other names and brands may be claimed as the property of others.

intel

Luxury Range Cookers

- AEG - Electrolux
- Belling
- Baumatic
- Bosch
- Miele
- Neff
- Parkinson Cowan
- Zanussi













*Other names and brands may be listed on the product website.

intel

Category: Digital Home, Audio, Video, Security, Lighting



How Do We Capitalize on Luxury Purchasing?











Selling "The Luxury Experience"

- THX - Experience
- Expectancy Theory



(\$248 Retail)





(\$35,000 - \$120,000 Retail)

*Other names and brands may be listed on the product of JBL



Managing Residential Projects



Proposals/Tenders

- How do you get Residential Jobs??
 - Selling to the:
 - Builder
 - Contractor
 - Project Management
 - Contracting with the Home Owner
- Is Tendering a Good Thing?
- Proposal/Agreement/Contract
 - Review Sample Proposal



intel

The Market



Remodel/Additions



New Construction



Existing Homes

intel

New Construction Projects

- Over 25,000 New Home Starts in 2005
 - National House-Building Council
 - www.nhbc.co.uk
- Prime Decision Time
- Strict Construction Time Lines
- Self Build Option
 - Approx. 20,000/year
 - www.selfbuildit.co.uk
- Financing Options



intel

Timber Frame Statistics

- 17% of UK Market
- 1 in 6 New Homes
- 18% Growth Rate in 2004
 - 7.4% Growth for other construction methods



*Statistic courtesy of UK Timber Frame Association





Retrofit Projects





- Flexible Time Line – Maybe/Maybe NOT
- Complicated Wiring
- One Room Solutions
- Wireless Solutions
- May Lead to the WHOLE HOUSE





5 Phases of Whole Home Projects

(New Construction & Retrofit)

1. Design 
2. Rough-In 
3. Trim 
4. Finish 
5. Customer Hand-Off 



Design Phase

- Total Methodology
- Sets the Stage
 - "EXPERIENCE"
- Design For The Future
- Impacts Entire Project
- Specific Deliverables



Rough-In/Pre-Wire

- Use Design Documents
 - Blue Prints
 - Management Binder
- Get Wire Installed
- Accommodate Construction Schedule
- Build Partnerships
- Label Everything











Trim Phase

- 2-12 Months Later (over 90%)
- Dig Through
 - Dry-Wall, Paint, Cabinets
- Install
 - Faceplates, Speakers, Keypads, Switches
- Glad Somebody Labeled?



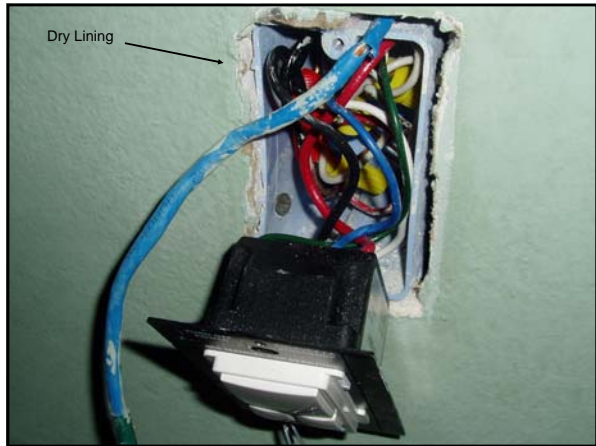

Finish Phase

- Equipment Racks
- Entertainment Centre
- Displays
- Energize Equipment
- Client Excitement





Customer Hand-Off

- Human Interfaces
 - Humanizing Technology
- Education
 - Practice





- Lasting Impressions
- Referrals???



Marketing Allies

- New Construction
 - Builders (Construction Industry Trade Alliance)
 - www.cita.co.uk
 - Architects (Association of Consultant Architects)
 - www.acarchitects.co.uk
 - Electrical Contractors Association
 - www.eca.co.uk
 - House Builders Federation – www.hbf.co.uk
- Retrofit
 - Home Building & Renovating Show
 - www.homebuildingshow.co.uk
 - British Interior Design Association
 - www.bida.org
 - Kitchen, Bathroom & Bedroom Specialists Association
 - www.ksa.org.uk



*Other names and brands may be claimed as the property of others.



Marketing Allies

- Developers
 - <http://www.ambrosdencourt.co.uk/>
- Other Tradesman



*Other names and brands may be claimed as the property of others.



Component Sourcing

Distribution

vs.

Direct Dealership



Component Selection

- Audio
 - Head End Gear
 - Amps, Receivers, Processors
 - Sources
 - Speakers
- Video
 - Head End Gear
 - Switchers/Routers
 - Sources
 - Displays



“Distributed Audio”

- Crestron – www.crestron.co.uk
- Elan – www.elanhomesystems.com
 - info@elansystemsuk.com
- Intel – www.intel.com
- Kramer – www.kramerelectronics.co.uk
- Russound – www.russound.com
 - www.multi-room.com
- Sonance – www.sonance.com
 - info@vedacustominstall.co.uk
- Sonos – www.sonos.com
- Speaker Craft – www.speakercraft.com
 - www.csesolutions.co.uk

*Other names and brands may be claimed as the property of others.



Speakers

- JBL – www.jbl.com
 - info.uk@harman.com (Harmon Consumer Office)
- Kef - <http://www.kef.co.uk/>
- Klipsch – www.klipsch.com
 - www.realtimeltd.co.uk (Distributor)
- Speakercraft – www.speakercraft.com
 - mqhungate@aol.com
- Sonance – www.sonance.com
 - info@vedacustominstall.co.uk
- Tannoy – www.tannoy.co.uk
- Triad - **Gecko Inc. Ltd.** info@gecko.uk.com

*Other names and brands may be claimed as the property of others.

intel

Distributed Video

- Autopatch – www.autopatch.com
- Crestron – www.crestron.com.uk
- Extron – www.extron.com
- Orb – www.orb.com
- Intel – www.intel.com
- Sonance – www.sonance.com
 - info@vedacustominstall.co.uk

©2006 Intel and Intel logo are trademarks of Intel Corporation.

intel

Displays

- DLP
 - Optoma
 - Samsung
- Plasma
 - LG
 - NEC
 - Panasonic
- Projector
 - Benq
 - In-Focus
 - Optoma
 - Sim2
 - Runco

Sources

- AWE Europe
 - www.awe-europe.co.uk
- Benq
 - www.benq.co.uk
- CSE
 - www.csesolutions.co.uk
- Optoma
 - www.optomaeurope.com
- Projectorcentral.com
- Sharp
 - www.sharp.co.uk
- Sim2
 - www.sim2.co.uk

intel

Lighting

- Lutron
 - www.lutron.com/europe
- Luxum
 - www.luxum.be
- RakoControls
 - <http://www.rakocontrols.com/>
- X-10
 - www.martek.nu







ConvergeX

- Media Centre Based
- Microsoft .net Platform
- UPnP
- X10
- ZWave
- Member of Intel Developer Network





Home Automation

- Harmony for Media Centre
 - www.idomus.co.uk



X-10 Touchscreen



*Other names and brands may be claimed as the property of others



Accessories

- Home Theater Acoustics
 - www.acoustiblokuk.com
- DVI Gear – Digital Cabling
 - www.dvigeart.com
- Liberty Cable – Wiring Infrastructure
 - www.csesolutions.co.uk
- MiddleAtlantic – Equipment Racks
 - www.middleatlantic.com
 - www.rqbcomms.co.uk
- Transparent – High-End Interconnects
 - www.transparentcable.com



Miscellaneous Resources

- Integration Trade Show
 - www.iseurope.org –
 - Brussels Expo, Belgium
 - 1-3 February, 2006
- CEDIA
 - www.cedia.co.uk
 - 19-22 June, 2006
- Net @ Home Event (8 years)
 - <http://www.net-at-home.com/>
 - Intel's Matt Theall to keynote Net-atHome™2005!
- Smart Home Show www.smarthomeshow.co.uk

*Other names and brands may be claimed as the property of others.



Miscellaneous Resources

- Magazines
 - www.digitalhomemag.com
- General Resource
 - www.hiddenwires.co.uk
- MCE Resource
 - www.mediaCentrepeworld.com/

*Other names and brands may be claimed as the property of others.



UK Product Sources













The Multi-Room Company Ltd
 4 Churchill House
 Churchill Road
 Cheltenham
 GL53 7EG

Tel: 01242 539100

www.multi-room.com

*Other names and brands may be claimed as the property of others.

intel

General Distribution

- AWE Europe -
 - <http://www.awe-europe.co.uk/>
- BMB Electronics
 - www.bmbelectronics.nl
- CSE Distribution
 - www.csesolutions.co.uk
- Future Home
 - A/V Gear
 - www.futurehome.co.uk
- Martek Electronics
 - X-10 Powerline
 - Xantech – Distributed A/V
 - www.martekuk.co.uk

*Other names and brands may be claimed as the property of others.

intel

Emerging Technologies

- Wireless Control
 - Zigbee- www.zigbee.org
 - www.atalum.com (OEM)
 - Z-Wave
 - www.zwavealliance.com
- Wireless HD Video
 - NEC – www.nec.com
- Powerline
 - UPB
 - www.simplyautomated.com



*Other names and brands may be claimed as the property of others.

intel

Emerging Technologies



- Xbox 360
 - Media Centre
 - Media Centre Extender
 - Xbox Live
- Designed For Home Environment
- 127 Antenna Signals
- MIMO for existing 802.11 Chipsets
 - Multiple-In / Multiple-Out
- BeamFlex QoS
- Wireless Management of:
 - Voice
 - Data
 - Video



MF2900

www.ruckuswireless.com

*Other names and brands may be claimed as the property of others.

intel

Q & A



Anything you'd like clarification on?



intel

See You Tomorrow!!



intel

Day 2 Goals

1. Audio
 1. Distributed Audio
 2. Home Theater Audio
2. Video
 1. Distributed Video
 2. Displays
3. Hands-On Experience
4. Demonstrations



Distributed Audio Strategies

1. Room Selector Box
2. Remote Switching – Line Level
3. Remote Switching – Cat5
4. Digital Streaming
 1. Wired
 2. Wireless



Define “Room” and “Zone”

1. Room = Room Name
2. Zone = Amp Loading

Kitchen

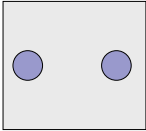

Dining

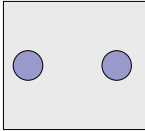

M Bed

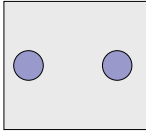



Define Room and Zone

- 3 Rooms
- 3 Zones

Kitchen

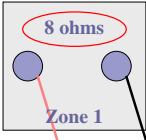

Dining

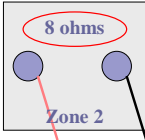

M Bed

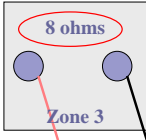

intel

Define Room and Zone

- 3 Rooms
- 3 Zones

intel

Define Room and Zone

- 3 Rooms
- 2 Zones

intel

Define Room and Zone

- 3 Rooms
- 1 Zone

DANGER

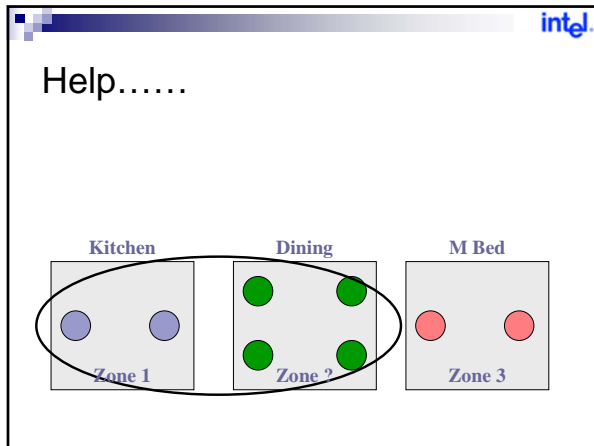

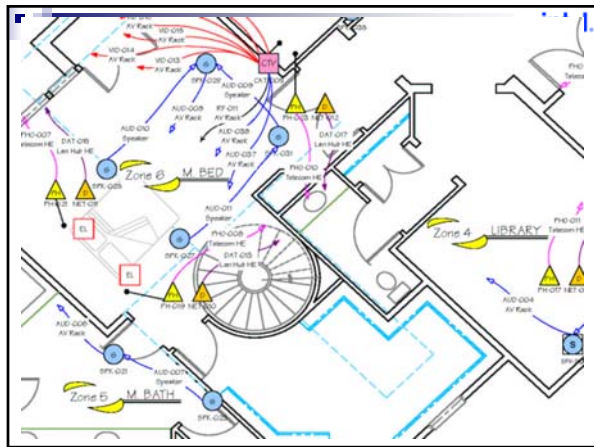

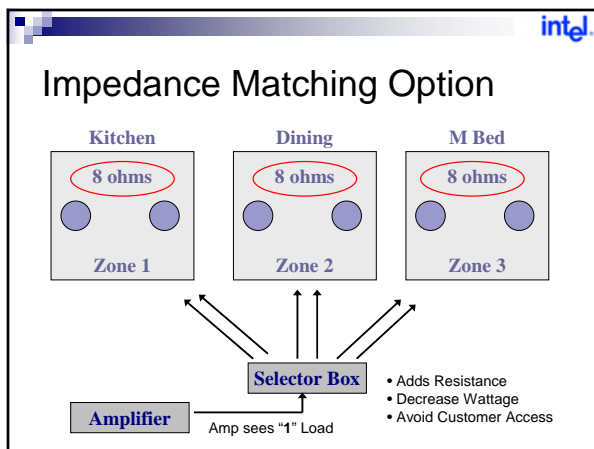

intel

Hands On Sessions

intel

Home Theater



intel

Definition

Home Theater System



Home Theater



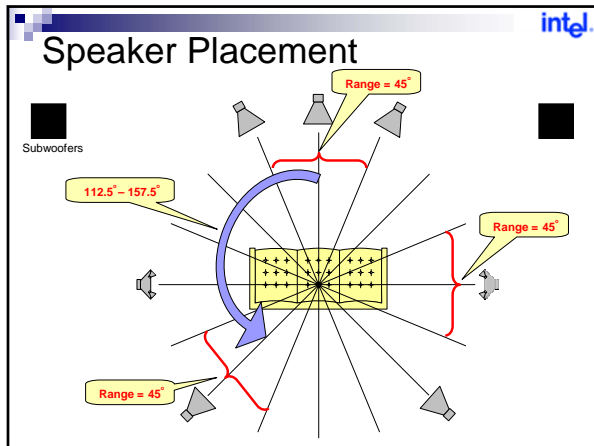

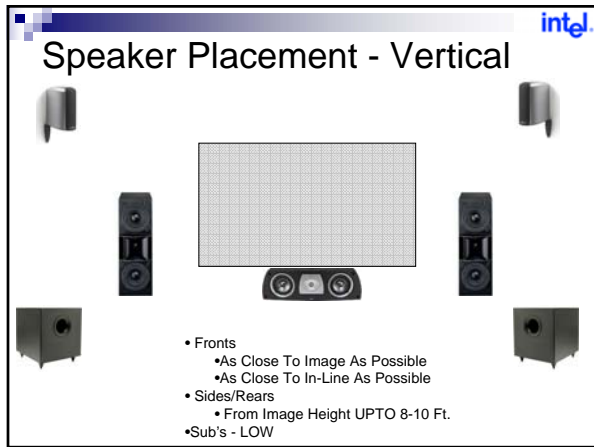



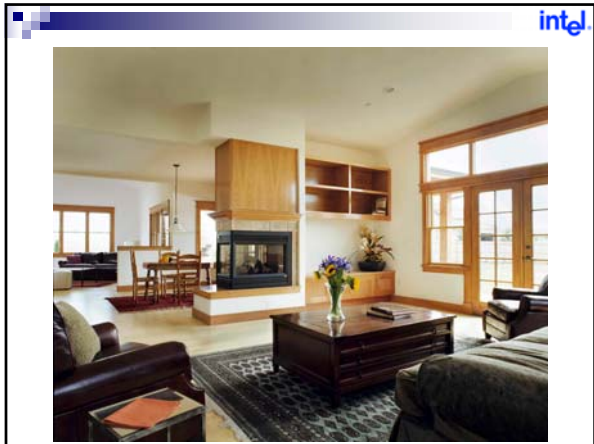

intel

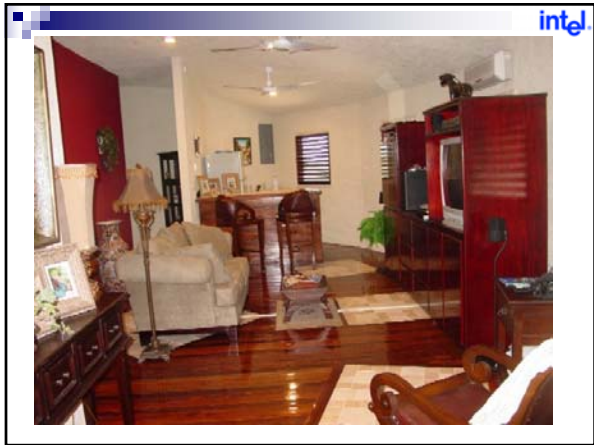

intel



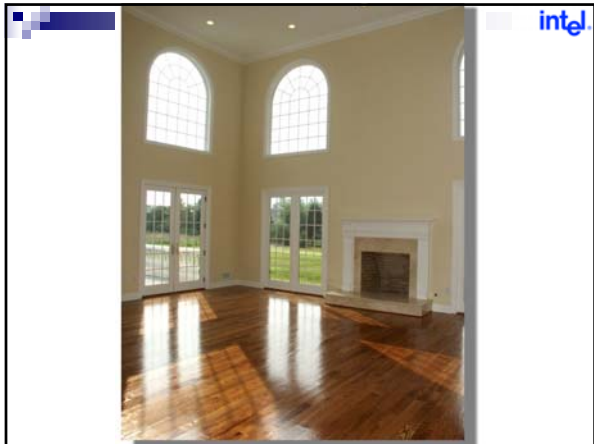

intel



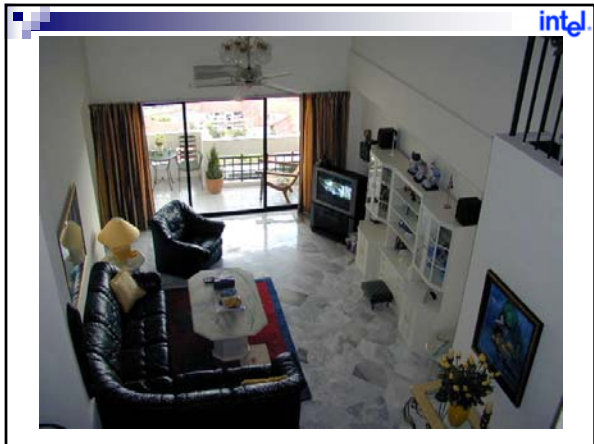

intel

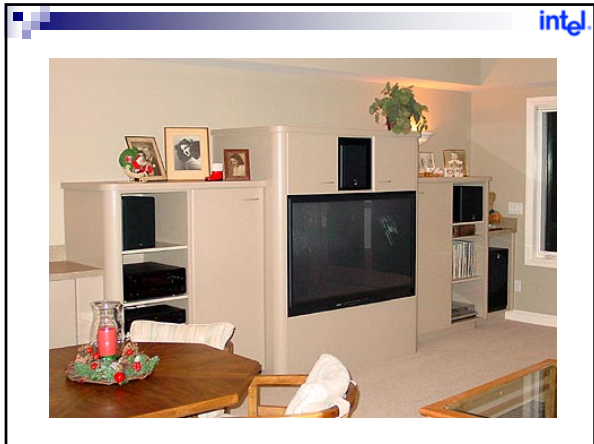





intel

Bipole Speaker

JBL Synthesis S4A – 3 Mode Configurable (Dipole/Bipole/Direct Radiating)

intel

Dipole Speaker

JBL Synthesis S4A – 3 Mode Configurable (Dipole/Bipole/Direct Radiating)



intel

Quadpole Speaker

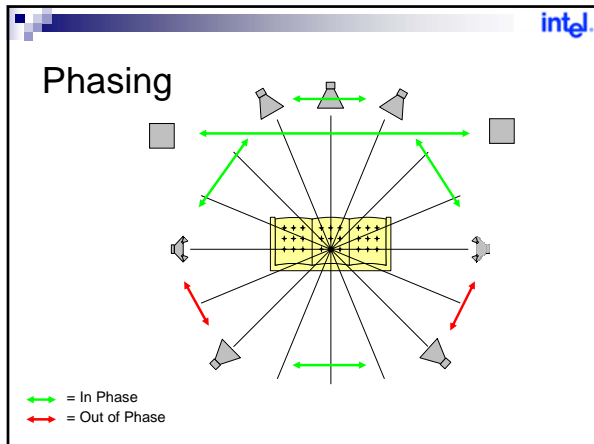
Axiom OS8 Quadpole *Other names and brands may be claimed as the property of others.





-
- ### Critical Audio Specifications
- **Speakers**
 - Maximum Wattage – Higher Is Better
 - Frequency Response - Wider Is Better
 - Nominal Wattage - Lower Is Better
 - **Amplifiers**
 - Maximum Wattage - Higher Is Better
 - Ohm - Lower Is Better
 - # of Channel Outputs – Application Specific

-
- ### Audio Definitions
- **Dolby** – Recording Format
 - Dolby NR
 - Dolby Surround
 - Dolby Pro Logic (IIx)
 - **DTS** – Rival to Dolby
 - **THX** – Playback Quality Control
 - **Crossover** – Frequency Control Electronic Filters
- 
- 
- 

intel

Content / Media

- CD's
- Downloads
 - Varied Quality
- SACD = Super Audio Compact Disc
 - Hybrid – CD and SACD Layer
 - Single Layer
 - Dual Layer
- DVD Audio
 - May contain
 - Menus
 - Video
 - Better Copy Protection

*Other names and brands may be claimed as the property of others.

intel

Audio Sources



Ipod – In-wall Cradle



CD Changer



Media Server

*Other names and brands may be claimed as the property of others.

intel

Audio Cabling

- Line Level
- Speaker Level (Amplified)
 - 8-16 AWG
- Interconnects
 - Analog
 - S/PDIF = Sony/Philips Digital Interface
 - Digital Electrical Transmission
 - TOSLink™ = Digital Light Transmission
 - Light Source = Red LED
 - Registered Trademark of Toshiba







*Other names and brands may be claimed as the property of others.

intel

Hands On Sessions

intel

Distributed Video Strategies

1. Distributed RF
2. Distributed:
 1. Composite
 2. Component
 3. S-Video
3. Cat5 Analog Distribution
4. Digital Streaming
 1. Wired
 2. Wireless

intel

Distributed RF

- Least Expensive
- Least Amount of Cable
- Lacks Expandability
- Lowest Quality



intel

Distributed; Composite, S-Video, & Component

- Best for expandability
- Easily add sources to Head-End
- Add cost for switching equipment

intel

Distributed; Composite, Component, & S-Video

```
graph TD; Source[Source] --> VideoRouter[Video Router]; VideoRouter --> TV1((TV)); VideoRouter --> TV2((TV)); VideoRouter --> TV3((TV)); VideoRouter --> TV4((TV)); VideoRouter --> TV5((TV)); VideoRouter --> TV6((TV));
```

intel

S-Video Router/Switcher

*Other names and brands may be claimed as the property of others.

Cat5 Distribution

- Recent addition to the industry
- Different approaches being pursued
- Digital & Analog



Wall Ports

- UNICOM
- £ 40/Each
- Anixter
- 1080i up to 30m
- 480p & 720p up to 100m

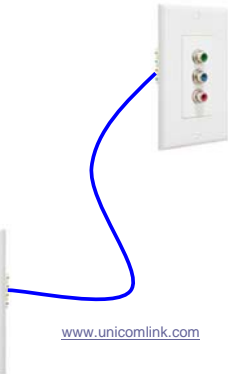

www.unicomlink.com

Remote Switching – Cat 5

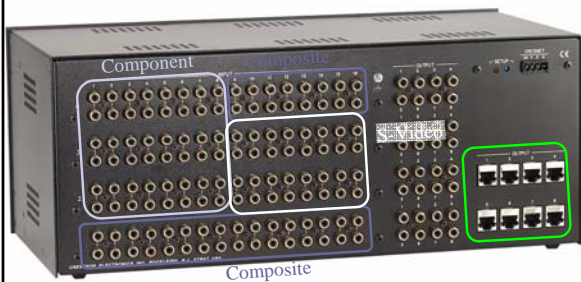

*Other names and brands may be claimed as the property of others.

intel

Digital Streaming



- Most Flexible
- Better Content Management
- Easily Configured
- Very Expandable



intel

Bandwidth

- HD Video – 320 Mbps (uncompressed)
- HD Video – 18 Mbps (MPEG 2)
- HD Video -

intel

Hands On Sessions

intel

Displays

1365 x 768
WXGA
61 inch

© 2006 Intel Corporation. All rights reserved. Intel, the Intel logo, and Intel Inside are trademarks or registered trademarks of Intel Corporation or its subsidiaries in the United States and other countries.

intel

Analog TV – PAL Analog

625
540
720

*25 fps
*50 Hz

intel

High Definition

1080
1920

intel

Acronym Help

- HDTV – 720p or 1080i
- EDTV – 576p
- SDTV – 625i
- DTV



intel

Display Types

- Televisions
 - Analog, Digital
- Rear Projection
 - CRT – Cathode Ray Tube
 - DLP – Digital Light Processor
- Projectors
 - DLP – Digital Light Processing
 - LCD – Liquid Crystal Display
 - LCOS – Liquid Crystal on Silicon
 - D-ILA – direct Drive Image Light Amplifier
- Flat Panel
 - Plasma
 - LCD

intel

DLP Technology (Texas Instruments)

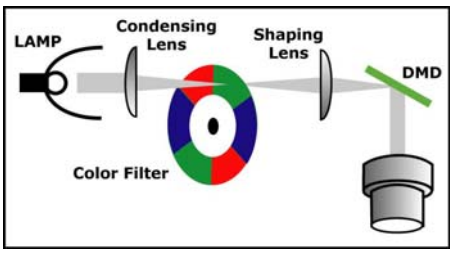

DMD = Digital MicroMirror Device

*Other names and brands may be claimed as the property of others.

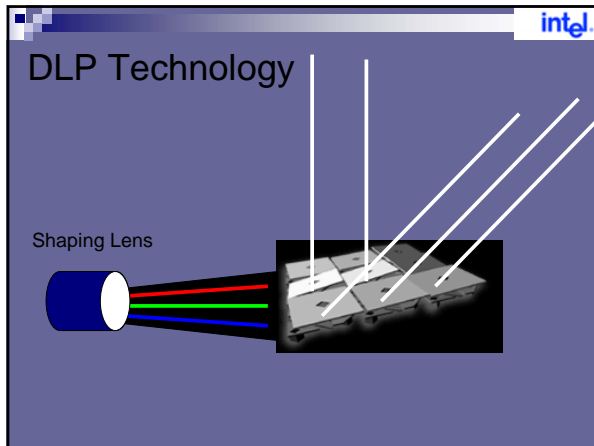

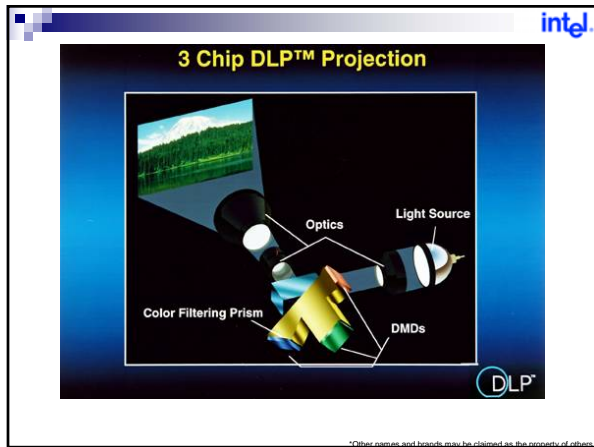

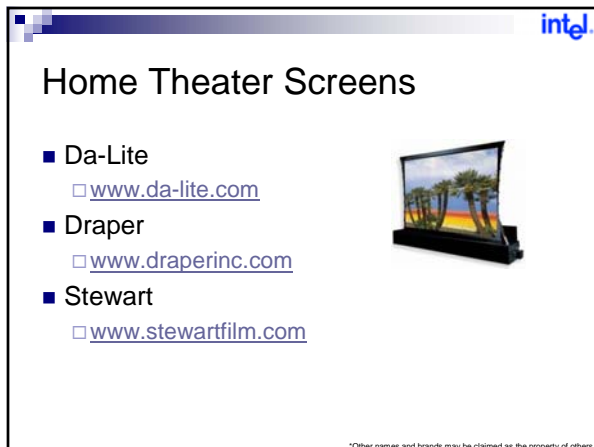

intel

HD LCD

- Sharp
- LC45GD6U
- 45"
- 1080p
- £ 3,000



A Sharp LC45GD6U HD LCD television is shown, displaying a vibrant underwater scene with various fish swimming in clear blue water. The TV is a large, flat-screen model with a silver stand.

intel

HD Plasma

- Pioneer
- 43"
- 720p
- £ 2,500



A Pioneer HD Plasma television is shown, displaying the text "HD ready" on its screen. The TV is a large, flat-screen model with a silver stand, and a small external device is visible to its right.





Flat Panel Options: Plasma v. LCD

Plasma: Wide field of view of more than 160°

<ul style="list-style-type: none"> •Brightness •Contrast 	<ul style="list-style-type: none"> •Power Consumption •Lifespan
--	---

Source's

- VCR's – 288 Lines
 - Interlaced or Interlaced
- DVD Players – 576
 - Progressive or Interlaced
- Sky Set top Box – 576 to 1080p
- Media Server 1080i (Philips)

Media Server

intel

LG DVB418



- Region Free
- HDMI, Component, S-Video,
- Optical, Coaxial Digital Audio
- 1080i Upconversion
- £ 200 (approx)

*Other names and brands may be included for the purposes of illustration.

intel

DVI Connectors (Digital)



- 30-50 ft. maximum
 - Depending on cable, source, & display
- No field termination
- No Audio

intel

HDMI - *High Definition Multimedia Interface*



- 30-50 ft. maximum
 - Depending on cable, source, & display
- No field termination
- Carries Digital Video, Audio, & Control Signals (i.e. signal control)(i.e. DRM)

intel

Analog Y, Pb, Pr



INPUT (component)

- Up to 200 ft. lengths
- Field termination common
- Y = Green + Luminance + HSync + VSync)
- Pb = Blue - Luminance
- Pr = Red - Luminance

intel

RGBHV



- 200' + Common
- Commercial Applications
- Field Termination is Common

*Other names and brands may be claimed as the property of others.

intel

Signal Conversion

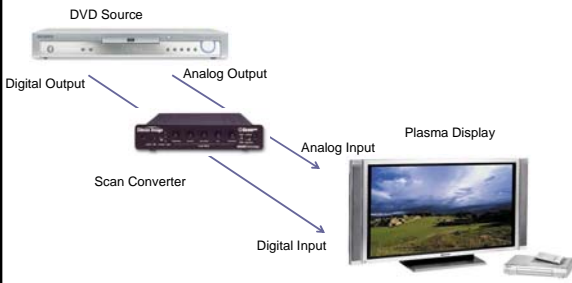

DVD Source

Digital Output

Analog Output

Scan Converter

Analog Input

Digital Input

Plasma Display

*Other names and brands may be claimed as the property of others.

intel

Aspect Ratio

- 4:3 or 1.33:1
- 16:9 or 1.78:1
- Letter Box

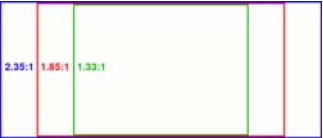
intel





Original Film

Anamorphic Lens

intel

Content / Media

- DVD's
- Blu-Ray – Sony vs. HD DVD- Toshiba/NEC
- Satellite
- Downloads
 - Internet
 - IPTV (Microsoft / BT / Phillips)
 - Microsoft TV IPTV Edition
 - Philips Set-Top Box w/ 80 hr. PVR
 - Autumn 2006





*Other names and brands may be claimed as the property of others

intel

Demo

intel



Go forth and be **profitable!!!**



intel

Please Submit Class Surveys



Reference Material

- "Trading Up" – Michael J. Silverstein & Neil Fiske
- "Let's Get Real or Let's Not Play" – Mahan Khalsa
- "Selling the Invisible" – Harry Beckwith
- "Networking with Millionaires" – Thomas Stanley
- "Priceless" – Diana LaSalle & Terry A. Britton
- "How Customers Think" – Gerald Zaltman
- "Good to Great" – Jim Collins
- "Living it Up" – James B. Twitchell
- "Positive Words, Powerful Results" – Hal Urban
- "Dig Your Well Before Your Thirsty" – Harvey Mackay
- "The Power To Decide Workshop" – Brian Tracy (Live)
- "Free Agent Nation" – Daniel Pink
- "The Decline of BRANDS" – Wired Magazine 11/2004



Equipment Lists

Entertainment Equipment	Displays
<ul style="list-style-type: none"> 1ea. - HK AVR 135 1ea. - HK AVR 635 1ea. - JBL SCS200.7 2pr. - JBL FS400 2pr. - JBL N24AW 1pr. - JBL S36ii 1pr. - JBL HT4V 1ea. - JBL HT4H 1pr. - JBL HT5 1ea. - JBL HTPS400 1ea. - JBL AV1 1ea. - JBL AVA7 1ea. - Audioaccess PX-700 1ea. - Audioaccess MA-362 1ea. - Audioaccess KPT 2ea. - Audioaccess KPS-101 1ea. - Audioaccess CATC 1ea. - Samsung HD950 DVD 	<ul style="list-style-type: none"> 1ea. - Benq PE7700 Projector 1ea. - LG MU50PM10 Plasma 1ea. - Optoma RD50 Rear Projection 16 - NEC LCD1715 Flat Panel Monitors 1 - Crestron TPMC-10 Wireless Control



Contact Us:

For Advanced Training, Consulting, & Support Programs

<p><u>NASBA</u></p> <p>Jim Niekamp VP Sales & Marketing</p> <p>770.698-9955 (ph.) 770.698.9161 (fax)</p> <p>www.nasba.com</p>	<p><u>Roland Graham</u></p> <p>President AVDMedia, Inc.</p> <p>509.936.0590 (ph.) 509.935.6574 (fax)</p> <p>rgraham@avdmedia.com</p>
---	---
